

GATE VALVE STAINLESS STEEL FEMALE THREAD

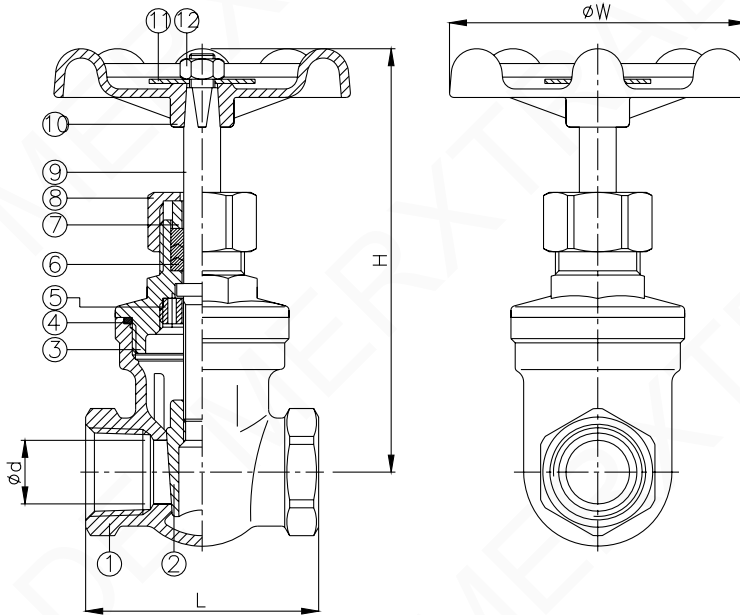

- 1/2" ~ 3" (DN15 ~ DN80)
- W.P. : 200 WOG PN16
- W.T. : -20°C ~ 200°C (-4°F ~ 392°F)
- Investment casting
- Non-rising stem

- Thread type : ASME B1.20.1 (NPT)
DIN2999 & BS21
ISO7/1 & EN10226



ITEM	PARTS	MATERIAL	
1	BODY		
2	DISC	ASTM A351-CF8M	ASTM A351-CF8
3	BONNET		
4	SEAL	PTFE	
5	GASKET	AISI 304	
6	PACKING	PTFE	
7	GLAND RING	AISI 304	
8	CAP NUT	ASTM A351-CF8M	ASTM A351-CF8
9	STEM	AISI 316	AISI 304
10	HANDLE	ALUMINUM	
11	NAMEPLATE		
12	NUT	AISI 304	

DN	d	L	H	W	Weight (kg)
15	15	55	101	70	0.4
20	20	60	108	70	0.5
25	25	65	118	80	0.7
32	32	75	132	80	1
40	38	85	149	90	1.4
50	50	95	175	100	2.1
65	65	116	213	140	5.8
80	80	130	241	140	8.8

unit:mm

NPS	d	L	H	W	Weight (lb)
1/2"	0.59	2.17	3.98	2.76	1
3/4"	0.79	2.36	4	2.76	1.2
1"	0.98	2.56	4.65	3.15	1.5
1-1/4"	1.26	2.95	5.2	3.15	2.2
1-1/2"	1.5	3.35	5.87	3.54	3.1
2"	1.97	3.74	6.89	3.94	5
2-1/2"	2.56	4.57	8.39	3.94	12.8
3"	3.15	5.12	9.49	5.51	19.4

unit:in